

<b>Addendum for:</b> <b>TECHNICAL DESIGN REQUIREMENTS FOR ALBERTA INFRASTRUCTURE FACILITIES, SEPTEMBER 4, 2024</b>	
<b>Addendum No.:</b> <b>2</b>	
<b>Contents:</b> <b>Updates to: Appendix I, "Workspace Furniture Typical"</b>	
<b>Contact:</b> <b>Julie Huk      julie.huk@gov.ab.ca</b> <b>825-993-1081</b>	<b>Issued Date:</b> <b>2024-09-04</b>

<p><u>Appendix I</u> – Workspace Furniture Typical:</p> <ul style="list-style-type: none"> <li>New Detail 1 (attached)</li> <li>New Detail 2 (attached)</li> <li>New Detail 3 (attached)</li> <li>New Detail 4 (attached)</li> <li>New Detail 5A (attached)</li> <li>New Detail 5B (attached)</li> <li>New Detail 6 (attached)</li> <li>New Detail 7 (attached)</li> </ul>	

# WORKSPACE LEGEND:

ELECTRICAL/VOICE/DATA LEGEND (TYPICAL):

Ⓞ DUPLEX OUTLET

▲ VOICE/DATA

⊠ POWER FEED

**NOTE:**

1. PROVIDE ALL NECESSARY ELECTRICAL AND POWER HARNESSSES/CABLING REQUIRED.
2. IN paneled workspaces, locate electrical in base. provide cable management.

**PANELS:**

PANELS SHALL BE COMPRISED OF 1 (ONE) MANUFACTURER'S STANDARD HEIGHT BASE PANEL AND 1 (ONE) LOAD BEARING STACKED PANEL TO ACHIEVE AN OVERALL HEIGHT OF 54"± (1372 mm±) TO 60"(1524mm).

PANEL WIDTHS SHALL BE 24" (610mm) , 30" (762mm), 42" (1067mm), OR 48" (1219mm) AS REQUIRED TO ACHIEVE THE OVERALL LAYOUT.

**NOTE:**

DRAWINGS TO BE READ IN CONJUNCTION WITH THE TECHNICAL DESIGN REQUIREMENTS (TDR).

OPTIONAL: GLASS MAY BE ADDED BASED ON PROJECT REQUIREMENTS.

ANY DISCREPANCIES SHALL BE BROUGHT TO THE ATTENTION OF TECHNICAL SERVICES.

	CONSULTANT	PROJECT	DRAWN BY	CHECKED BY	SCALE
		TECHNICAL DESIGN REQUIREMENTS VERSION 7- ADDENDUM #1	<b>JH</b>	<b>KM</b>	<b>NTS</b>
	DOCUMENT CODE WORKSPACE FURNITURE TYPICALS_APPENDIX I_TDR.V7 ADD_2024	TITLE	DATE	SITE ID	BUILDING ID
	TYPICAL WORKSPACE- LEGEND AND NOTES	<b>2024-09-04</b>	-	-	
		PLAN NO.	PHASE	DISCIPLINE	
		-	-	-	
		PROJECT ID.	SHEET NO.		
		<b>Appendix I</b>			<b>A</b>

## WORKSPACE KIT-OF-PARTS LEGEND:

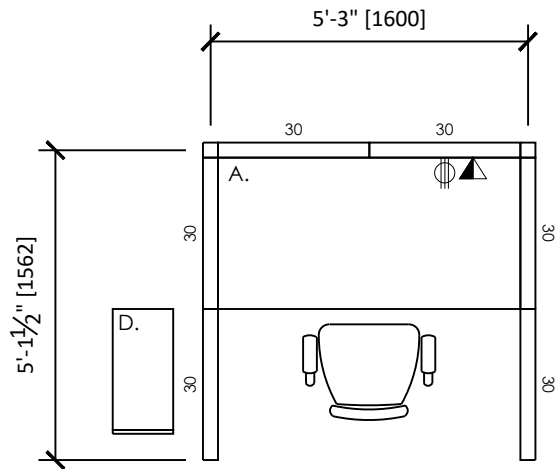

1 HOTELING WORKSPACE  
2.5 m<sup>2</sup>

### WORKSTATION FINISHES:

**WORKSURFACE TOPS:** H.P. PLASTIC LAMINATE C/W STANDARD MATCHING EDGE

**LAMINATE:** STANDARD GRADE (INCLUDES WOODGRAIN LAMINATE OPTIONS)

**LEGS/BASE:** STANDARD PAINTED METAL FINISH (INCLUDES METALLIC OPTIONS)

**STORAGE TOWER:** LAMINATE OR STANDARD PAINTED METAL FINISH

**STANDARD PULL** (ADA COMPLIANT)

### PANEL FINISHES:

**CLEAR OR FROSTED SINGLE PANE GLASS** - FRAMELESS (ACRYLIC IS NOT ACCEPTABLE)

**PANEL FABRIC:** GRADE 2/B FABRIC

**TOP, END & CORNER TRIMS:** FULL-LENGTH, STANDARD PAINTED METAL FINISH (INCLUDES METALLIC OPTIONS)

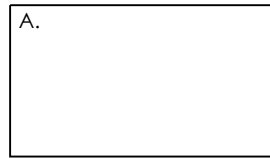

### A. PRIMARY WORKSURFACE

- 30" D x 60" W (762 mm D x 1372 mm W)
- ELECTRIC HEIGHT ADJUSTABLE
- CABLE MANAGEMENT ALONG BACK

### D. STORAGE TOWER

- 12" W x 24" D x 54" ± H (305 mm W x 610 mm D x 1372 mm ± H)
- COAT ROD INCLUDED
- ANTI-TIP
- SIMILAR OVERALL HEIGHT AS STACKED PANEL
- LOCATE OUTSIDE OF WORKSPACE

### GENERAL NOTES

1. REFER TO LEGEND SHEET A, AND SECTION 3 OF THE TECHNICAL DESIGN REQUIREMENTS.
2. TYPICAL PANEL THICKNESS IS 3" ± (76 mm ±) AS PER MANUFACTURER'S STANDARD.
3. AS COMMON PANELS ARE SHARED WHEN THEY ARE GANGED TOGETHER, THE AREA FOR AN INDIVIDUAL WORKSPACE IS BASED ON THE CENTERLINE OF THE PANEL.
4. WORKSURFACES AND STORAGE SHALL HAVE DIMENSIONAL LOGIC AND CONSISTENCY.
5. ALL WORKSURFACES TO BE FREE-STANDING (NON-PANEL HUNG).
6. CHAIRS ARE SHOWN FOR ILLUSTRATION ONLY.
7. OPTIONAL: GLASS MAY BE ADDED BASED ON PROJECT REQUIREMENTS.

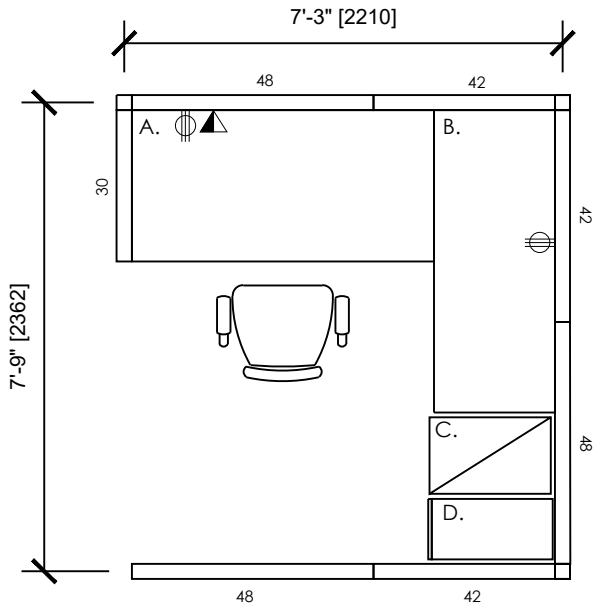

2 ROVER WORKSPACE  
5.2 m<sup>2</sup>

## WORKSPACE KIT-OF-PARTS LEGEND:



### A. PRIMARY WORKSURFACE

- 30" D x 60" W (762 mm D x 1524 mm W)
- ELECTRIC HEIGHT ADJUSTABLE
- CABLE MANAGEMENT ALONG BACK

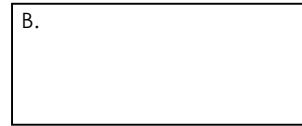

### B. SECONDARY WORKSURFACE

- 24" D x 60" W (610 mm D x 1524 mm W)
- PIN HEIGHT ADJUSTABLE POST LEGS (C-LEGS OPTIONAL)
- CABLE MANAGEMENT ALONG BACK

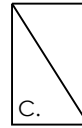

### C. MOBILE PEDESTAL w/ CUSHION TOP

- 22"-24" D (560mm-610 mm D)
- BOX/FILE DRAWERS c/w DIVIDERS, LEGAL/LETTER FILE HANGING BARS, PENCIL TRAY



### D. STORAGE TOWER

- 12" W x 24" D x 54"± H (305 mm W x 610 mm D x 1372 mm ± H)
- COAT ROD INCLUDED
- ANTI-TIP
- SIMILAR OVERALL HEIGHT AS STACKED PANEL

### WORKSTATION FINISHES:

**WORKSURFACE TOPS:** H.P. PLASTIC LAMINATE C/W STANDARD MATCHING EDGE

**LAMINATE:** STANDARD GRADE (INCLUDES WOOD GRAIN LAMINATE OPTIONS)

**LEGS/BASE:** STANDARD PAINTED METAL FINISH (INCLUDES METALLIC OPTIONS)

### MOBILE BOX, FILE PEDESTAL w/ CUSHION TOP:

**CUSHION TOP:** GRADE 2/B FABRIC

**BODY:** STANDARD PAINTED METAL FINISH

**STANDARD PULLS** (ADA COMPLIANT)

**STORAGE TOWER:** LAMINATE OR STANDARD PAINTED METAL FINISH

**STANDARD PULL** (ADA COMPLIANT)

### PANEL FINISHES:

**CLEAR OR FROSTED SINGLE PANE GLASS** - FRAMELESS (ACRYLIC IS NOT ACCEPTABLE)

**PANEL FABRIC:** GRADE 2/B FABRIC

**TOP, END & CORNER TRIMS:** FULL-LENGTH, STANDARD PAINTED METAL FINISH (INCLUDES METALLIC OPTIONS)

### GENERAL NOTES

1. REFER TO LEGEND SHEET A, AND SECTION 3 OF THE TECHNICAL DESIGN REQUIREMENTS.
2. TYPICAL PANEL THICKNESS IS 3"± (76 mm ±) AS PER MANUFACTURER'S STANDARD.
3. AS COMMON PANELS ARE SHARED WHEN THEY ARE GANGED TOGETHER, THE AREA FOR AN INDIVIDUAL WORKSPACE IS BASED ON THE CENTERLINE OF THE PANEL.
4. WORKSURFACES AND STORAGE SHALL HAVE DIMENSIONAL LOGIC AND CONSISTENCY.
5. ALL WORKSURFACES TO BE FREE-STANDING (NON-PANEL HUNG).
6. ALL STORAGE TO BE LOCKABLE AND KEYED ALIKE.
7. CHAIRS ARE SHOWN FOR ILLUSTRATION ONLY.
8. OPTIONAL: GLASS MAY BE ADDED BASED ON PROJECT REQUIREMENTS.

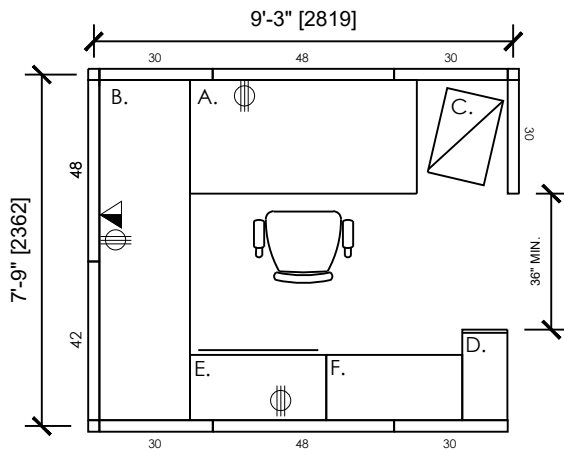

3 RESIDENT WORKSPACE  
6.7 m<sup>2</sup>

**WORKSTATION FINISHES:**

**WORKSURFACE TOPS:** H.P. PLASTIC LAMINATE C/W STANDARD MATCHING EDGE

**LAMINATE:** STANDARD GRADE (INCLUDES WOODGRAIN LAMINATE OPTIONS)

**LEGS/BASE:** STANDARD PAINTED METAL FINISH (INCLUDES METALLIC OPTIONS)

**MOBILE BOX, FILE PEDESTAL w/ CUSHION TOP:**

**CUSHION TOP:** GRADE 2/B FABRIC

**BODY:** STANDARD PAINTED METAL FINISH

**STANDARD PULLS** (ADA COMPLIANT)

**STORAGE TOWER:** LAMINATE OR STANDARD PAINTED METAL FINISH

**STANDARD PULL** (ADA COMPLIANT)

**LOW STORAGE:**

LAMINATE OR STANDARD PAINTED METAL FINISH

STANDARD PULL (ADA COMPLIANT)

**OPEN SHELF:**

STANDARD PAINTED METAL FINISH

**WORKSPACE KIT-OF-PARTS LEGEND:**

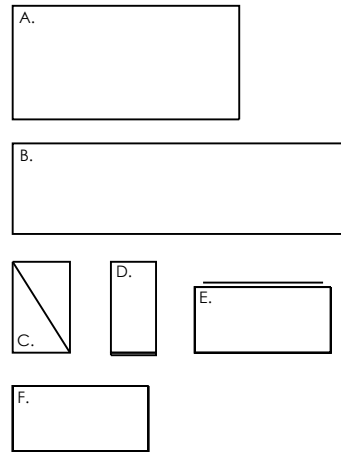

**A. PRIMARY WORKSURFACE**

- 30" D x 60" W (762 mm D x 1524 mm W)
- ELECTRIC HEIGHT ADJUSTABLE
- CABLE MANAGEMENT ALONG BACK

**B. SECONDARY WORKSURFACE**

- 24" D x 90" W (610 mm D x 2286 mm W)
- PIN HEIGHT ADJUSTABLE POST LEGS (C-LEGS OPTIONAL)
- CABLE MANAGEMENT ALONG BACK

**C. MOBILE PEDESTAL w/ CUSHION TOP**

- 22"-24" D (560mm-610 mm D)
- BOX/FILE DRAWERS c/w DIVIDERS, LEGAL/LETTER FILE HANGING BARS, PENCIL TRAY

**D. STORAGE TOWER**

- 12" W x 24" D x 54"± H (305 mm W x 610 mm D x 1372 mm ± H)
- COAT ROD INCLUDED
- ANTI-TIP
- SIMILAR OVERALL HEIGHT AS STACKED PANEL

**E. LOW FILE STORAGE (OPTIONAL)**

- 36" W x 18" D x 27"± H (914 mm W x 457 mm D x 686 mm ± H)
- 2 DRAWER LATERAL c/w DIVIDERS, LEGAL/LETTER FILE HANGING BARS
- FLUSH BACK AND FINISHED TOP
- ANTI-TIP

**F. LOW OPEN STORAGE (OPTIONAL)**

- 36" W x 18" D x 27"± H (914 mm W x 457 mm D x 686 mm ± H)
- ONE SHELF
- FLUSH BACK AND FINISHED TOP

**PANEL FINISHES:**

CLEAR OR FROSTED SINGLE PANE GLASS - FRAMELESS (ACRYLIC IS NOT ACCEPTABLE)

PANEL FABRIC: GRADE 2/B FABRIC

TOP, END & CORNER TRIMS: FULL LENGTH, STANDARD PAINTED METAL FINISH (INCLUDES METALLIC OPTIONS)

**GENERAL NOTES**

1. REFER TO LEGEND SHEET A, AND SECTION 3 OF THE TECHNICAL DESIGN REQUIREMENTS.
2. TYPICAL PANEL THICKNESS IS 3"± (76 mm ±) AS PER MANUFACTURER'S STANDARD.
3. AS COMMON PANELS ARE SHARED WHEN THEY ARE GANGED TOGETHER, THE AREA FOR AN INDIVIDUAL WORKSPACE IS BASED ON THE CENTRELINE OF THE PANEL.
4. WORKSURFACES AND STORAGE SHALL HAVE DIMENSIONAL LOGIC AND CONSISTENCY.
5. ALL WORKSURFACES TO BE FREE-STANDING (NON-PANEL HUNG).
6. ALL STORAGE TO BE LOCKABLE AND KEYED ALIKE.
7. COMPONENTS LISTED AS OPTIONAL CAN BE MIXED AND MATCHED, OR OMITTED.
8. CHAIRS ARE SHOWN FOR ILLUSTRATION ONLY.
9. OPTIONAL: GLASS MAY BE ADDED BASED ON PROJECT REQUIREMENTS.



CONSULTANT

DOCUMENT CODE

WORKSPACE FURNITURE TYPICALS\_APPENDIX I\_TDR.V7 ADD\_2024

PROJECT

TECHNICAL DESIGN REQUIREMENTS  
VERSION 7- ADDENDUM #1

TITLE

TYPICAL WORKSPACE- RESIDENT

DRAWN BY

JH

DATE

2024-09-04

PLAN NO.

-  
PROJECT ID.  
Appendix I

CHECKED BY

KM

SITE ID

-

PHASE

-

SCALE

NTS

BUILDING ID

-

DISCIPLINE

-

SHEET NO.

3

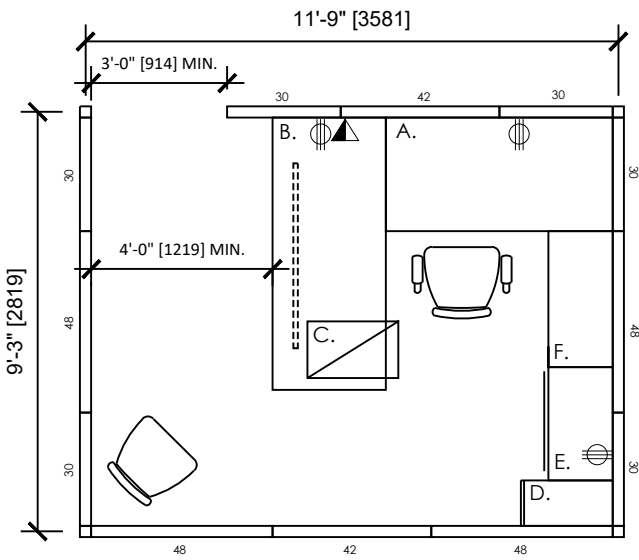

**4** DIRECTOR (AND EQUIVALENT) WORKSPACE  
10.1 m<sup>2</sup>

**WORKSTATION FINISHES:**

**WORKSURFACE TOPS:** H.P. PLASTIC LAMINATE C/W STANDARD MATCHING EDGE

**LAMINATE:** STANDARD GRADE (INCLUDES WOODGRAIN LAMINATE OPTIONS)

**LEGS/BASE:** STANDARD PAINTED METAL FINISH (INCLUDES METALLIC OPTIONS)

**MOBILE BOX, FILE PEDESTAL w/ CUSHION TOP:**

**CUSHION TOP:** GRADE 2/B FABRIC

**BODY:** STANDARD PAINTED METAL FINISH

**STANDARD PULLS** (ADA COMPLIANT)

**STORAGE TOWER:** LAMINATE OR STANDARD PAINTED METAL FINISH

**STANDARD PULL:** (ADA COMPLIANT)

**LOW STORAGE:** LAMINATE OR STANDARD PAINTED METAL FINISH

**STANDARD PULL:** (ADA COMPLIANT)

**PANEL FINISHES:**

**CLEAR OR FROSTED SINGLE PANE GLASS - FRAMELESS** (ACRYLIC IS NOT ACCEPTABLE)

**PANEL FABRIC:** GRADE 2/B FABRIC

**END, TOP, & CORNER TRIMS:** FULL LENGTH, STANDARD PAINTED METAL FINISH (INCLUDES METALLIC OPTIONS)

**WORKSPACE KIT-OF-PARTS LEGEND:**

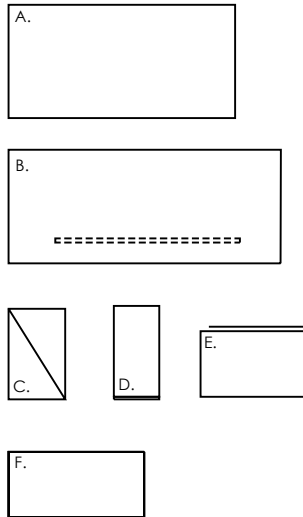

**A. PRIMARY WORKSURFACE**

- 30" D x 60" W (762 mm D x 1524 mm W)
- ELECTRIC HEIGHT ADJUSTABLE
- CABLE MANAGEMENT ALONG BACK

**B. SECONDARY WORKSURFACE**

- 30" D x 72" W (762 mm D x 1829 mm W)
- PIN HEIGHT ADJUSTABLE POST LEGS (C-LEGS OPTIONAL)
- HALF HEIGHT ' DETACHABLE' MODESTY PANEL
- CABLE MANAGEMENT ALONG SIDE

**C. MOBILE PEDESTAL w/ CUSHION TOP**

- 22"-24" D (560mm-610 mm D)
- BOX/FILE DRAWERS c/w DIVIDERS, LEGAL/LETTER FILE HANGING BARS, PENCIL TRAY

**D. STORAGE TOWER**

- 12" W x 24" D x 54"+/- H (305 mm W x 610 mm D x 1372 mm +/- H)
- COAT ROD INCLUDED
- ANTI-TIP
- SIMILAR OVERALL HEIGHT AS STACKED PANEL

**E. LOW FILE STORAGE (OPTIONAL)**

- 30" W x 18" D x 27"± H (914 mm W x 457 mm D x 686 mm ± H)
- 2 DRAWER LATERAL c/w DIVIDERS, LEGAL/LETTER FILE HANGING BARS
- FLUSH BACK AND FINISHED TOP
- ANTI-TIP

**F. LOW OPEN STORAGE (OPTIONAL)**

- 36" W x 18" D x 27"± H (914 mm W x 457 mm D x 686 mm ± H)
- ONE SHELF
- FLUSH BACK AND FINISHED TOP

**GENERAL NOTES**

1. REFER TO LEGEND SHEET A, AND SECTION 3 OF THE TECHNICAL DESIGN REQUIREMENTS.
2. TYPICAL PANEL THICKNESS IS 3"± (76 mm ±) AS PER MANUFACTURER'S STANDARD.
3. AS COMMON PANELS ARE SHARED WHEN THEY ARE GANGED TOGETHER, THE AREA FOR AN INDIVIDUAL WORKSPACE IS BASED ON THE CENTRELINE OF THE PANEL.
4. WORKSURFACES AND STORAGE SHALL HAVE DIMENSIONAL LOGIC AND CONSISTENCY.
5. ALL WORKSURFACES TO BE FREE-STANDING (NON-PANEL HUNG).
6. ALL STORAGE TO BE LOCKABLE AND KEYED ALIKE.
7. COMPONENTS LISTED AS OPTIONAL CAN BE MIXED AND MATCHED, OR OMITTED.
8. CHAIRS ARE SHOWN FOR ILLUSTRATION ONLY.
9. OPTIONAL: GLASS MAY BE ADDED BASED ON PROJECT REQUIREMENTS.



CONSULTANT
DOCUMENT CODE WORKSPACE FURNITURE TYPICALS_APPENDIX I_TDR.V7 ADD_2024

PROJECT TECHNICAL DESIGN REQUIREMENTS VERSION 7- ADDENDUM #1
TITLE TYPICAL WORKSPACE- DIRECTOR (& EQUIVALENT)

DRAWN BY <b>JH</b>	CHECKED BY <b>KM</b>	SCALE <b>NTS</b>
DATE <b>2024-09-04</b>	SITE ID -	BUILDING ID -
PLAN NO. -	PHASE -	DISCIPLINE -
PROJECT ID. <b>Appendix I</b>		SHEET NO. <b>4</b>

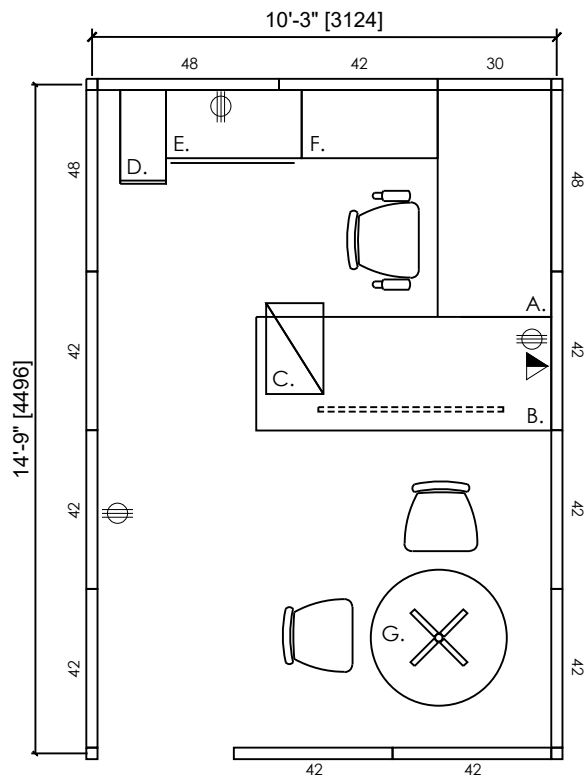

## WORKSPACE KIT-OF-PARTS LEGEND:

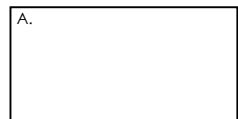

### A. PRIMARY WORKSURFACE

- 30" D x 60" W (762 mm D x 1524 mm W)
- ELECTRIC HEIGHT ADJUSTABLE
- CABLE MANAGEMENT ALONG SIDE

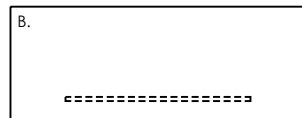

### B. SECONDARY WORKSURFACE

- 30" D x 78" W (762 mm D x 1982 mm W)
- PIN HEIGHT ADJUSTABLE POST LEGS (C-LEGS OPTIONAL)
- HALF HEIGHT 'DETACHABLE' MODESTY PANEL
- CABLE MANAGEMENT ALONG BACK

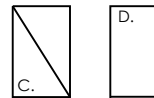

### C. MOBILE PEDESTAL w/ CUSHION TOP

- 22"-24" D (560mm-610 mm D)
- BOX/FILE DRAWERS c/w DIVIDERS, LEGAL/LETTER FILE HANGING BARS, PENCIL TRAY



### D. STORAGE TOWER

- 12" W x 24" D x 54"± H (305 mm W x 610 mm D x 1372 mm ± H)
- COAT ROD INCLUDED
- ANTI-TIP
- SIMILAR OVERALL HEIGHT AS STACKED PANEL

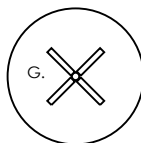

### E. LOW FILE STORAGE (OPTIONAL)

- 36" W x 18" D x 27"± H (914 mm W x 457 mm D x 686 mm ± H)
- 2 DRAWER LATERAL c/w DIVIDERS, LEGAL/LETTER FILE HANGING BARS
- FLUSH BACK AND FINISHED TOP
- ANTI-TIP

### F. LOW OPEN STORAGE (OPTIONAL)

- 36" W x 18" D x 27" ±H (914 mm W x 457 mm D x 686 mm ± H)
- ONE SHELF
- FLUSH BACK AND FINISHED TOP

### G. DESK HEIGHT TABLE

- 36" Dia. (914 mm Dia.)
- METAL "X" BASE

### GENERAL NOTES

1. REFER TO LEGEND SHEET A, AND SECTION 3 OF THE TECHNICAL DESIGN REQUIREMENTS.
2. TYPICAL PANEL THICKNESS IS 3"± (76 mm ±) AS PER MANUFACTURER'S STANDARD.
3. AS COMMON PANELS ARE SHARED WHEN THEY ARE GANGED TOGETHER, THE AREA FOR AN INDIVIDUAL WORKSPACE IS BASED ON THE CENTRELINER OF THE PANEL.
4. WORKSURFACES AND STORAGE SHALL HAVE DIMENSIONAL LOGIC AND CONSISTENCY.
5. ALL WORKSURFACES TO BE FREE-STANDING (NON-PANEL HUNG).
6. ALL STORAGE TO BE LOCKABLE AND KEYPED ALIKE.
7. COMPONENTS LISTED AS OPTIONAL CAN BE MIXED AND MATCHED, OR OMITTED.
8. THE EXECUTIVE DIRECTOR (AND EQUIVALENT) WORKSPACE IS EITHER AN OPEN WORKSTATION OPTION OR AN ENCLOSED OPTION.
9. CHAIRS ARE SHOWN FOR ILLUSTRATION ONLY.
10. OPTIONAL: GLASS MAY BE ADDED BASED ON PROJECT REQUIREMENTS.

5A EXECUTIVE DIRECTOR AND EQUIVALENT OPEN WORKSPACE OPTION  
14.0 m<sup>2</sup>

#### WORKSTATION FINISHES:

**WORKSURFACE TOPS:** H.P. PLASTIC LAMINATE C/W STANDARD MATCHING EDGE

**LAMINATE:** STANDARD GRADE (INCLUDES WOOD GRAIN LAMINATE OPTIONS)

**LEGS/BASE:** STANDARD PAINTED METAL FINISH (INCLUDES METALLIC OPTIONS)

#### PANEL FINISHES:

**CLEAR OR FROSTED SINGLE PANE GLASS - FRAMELESS** (ACRYLIC IS NOT ACCEPTABLE)

**PANEL FABRIC:** GRADE 2/B FABRIC

**END, TOP, & CORNER TRIMS:** FULL-LENGTH, STANDARD PAINTED METAL FINISH (INCLUDES METALLIC OPTIONS)

**MOBILE BOX, FILE PEDESTAL w/ CUSHION TOP:**

**CUSHION TOP:** GRADE 2/B FABRIC

**BODY:** STANDARD PAINTED METAL FINISH

**STANDARD PULLS** (ADA COMPLIANT)

**STORAGE TOWER:**

LAMINATE OR STANDARD PAINTED METAL FINISH, STANDARD PULL (ADA COMPLIANT)

**LOW STORAGE:**

LAMINATE OR STANDARD PAINTED METAL FINISH

STANDARD PULL (ADA COMPLIANT)



CONSULTANT

DOCUMENT CODE  
WORKSPACE FURNITURE TYPICALS\_APPENDIX I\_TDR.V7\_ADD\_2024

PROJECT

TECHNICAL DESIGN REQUIREMENTS  
VERSION 7- ADDENDUM #1

TITLE

TYPICAL WORKSPACE- OPEN OPTION  
EXECUTIVE DIRECTOR (& EQUIVALENT)

DRAWN BY

JH

DATE  
2024-09-04

PLAN NO.

-

PROJECT ID.  
Appendix I

CHECKED BY

KM

SITE ID  
-

PHASE

-

SHEET NO.  
5A

SCALE

NTS

BUILDING ID  
-

DISCIPLINE

-

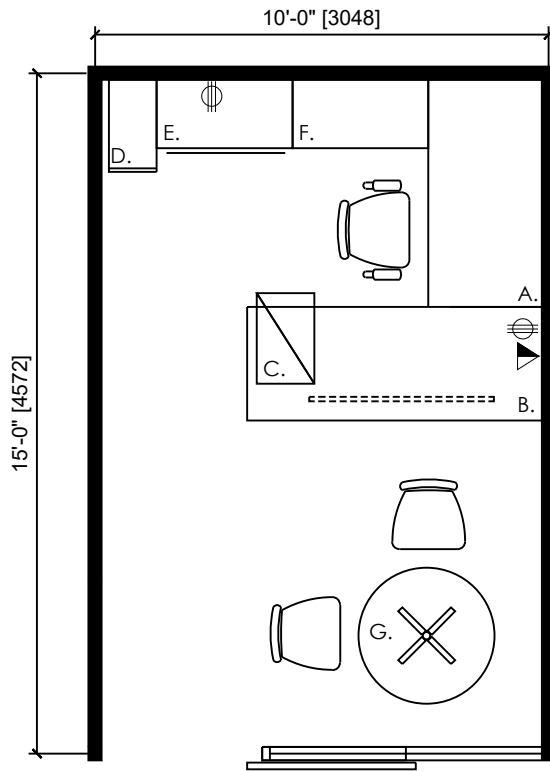

## WORKSPACE KIT-OF-PARTS LEGEND:

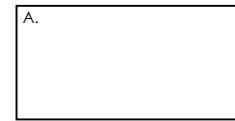

### A. PRIMARY WORKSURFACE

- 30" D x 60" W (762 mm D x 1524 mm W)
- ELECTRIC HEIGHT ADJUSTABLE
- CABLE MANAGEMENT ALONG SIDE

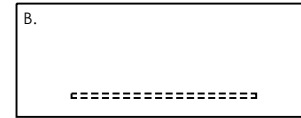

### B. SECONDARY WORKSURFACE

- 30" D x 78" W (610 mm D x 1982 mm W)
- PIN HEIGHT ADJUSTABLE POST LEGS (C-LEGS OPTIONAL)
- HALF HEIGHT 'DETACHABLE' MODESTY PANEL
- CABLE MANAGEMENT ALONG BACK

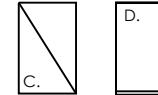

### C. MOBILE PEDESTAL w/ CUSHION TOP

- 22"-24" D (560mm-610 mm D)
- BOX/FILE DRAWERS c/w DIVIDERS, LEGAL/LETTER FILE HANGING BARS, PENCIL TRAY

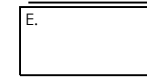

### D. STORAGE TOWER

- 12" W x 24" D x 54" ± H (305 mm W x 610 mm D x 1372 mm ± H)
- COAT ROD INCLUDED
- ANTI-TIP

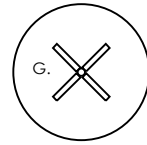

### G. DESK HEIGHT TABLE

- 36" Dia. (914 mm Dia.)
- METAL "X" BASE

### GENERAL NOTES

1. REFER TO LEGEND SHEET A, AND SECTION 3 OF THE TECHNICAL DESIGN REQUIREMENTS.
2. WORKSURFACES AND STORAGE SHALL HAVE DIMENSIONAL LOGIC AND CONSISTENCY.
3. WORKSPACE IS MEASURED FROM CENTRELINE OF WALL TO CENTRELINE OF WALL.
4. ALL WORKSURFACES TO BE FREE-STANDING (NON-PANEL HUNG).
5. ALL STORAGE TO BE LOCKABLE AND KEYPED ALIKE.
6. COMPONENTS LISTED AS OPTIONAL CAN BE MIXED AND MATCHED, OR OMITTED.
7. CHAIRS ARE SHOWN FOR ILLUSTRATION ONLY.
8. THE OVERALL LENGTH AND WIDTH OF THE ENCLOSED OFFICES MAY VARY TO SUIT SITE CONDITIONS, SO LONG AS THE SPACE REMAINS USEABLE, AND THE SIZE (SQ.M) IS MAINTAINED.

**5B** EXECUTIVE DIRECTOR (AND EQUIVALENT) ENCLOSED OFFICE OPTION  
14.0 m<sup>2</sup>

#### FINISHES:

**WORKSURFACE TOPS AND TABLE:** H.P. PLASTIC LAMINATE C/W STANDARD MATCHING EDGE

**LAMINATE:** STANDARD GRADE (INCLUDES WOOD GRAIN LAMINATE OPTIONS)

**LEGS/BASE:** STANDARD PAINTED METAL FINISH (INCLUDES METALLIC OPTIONS)

**MOBILE BOX, FILE PEDESTAL w/ CUSHION TOP:** GRADE 2/B FABRIC

**BODY:** STANDARD PAINTED METAL FINISH

**STANDARD PULLS** (ADA COMPLIANT)

#### STORAGE TOWER:

LAMINATE OR STANDARD PAINTED METAL FINISH

**STANDARD PULLS** (ADA COMPLIANT)

#### LOW STORAGE:

LAMINATE OR STANDARD PAINTED METAL FINISH

**STANDARD PULL** - METAL FINISH (ADA COMPLIANT)

#### CLOSED OVERHEAD:

LAMINATE OR STANDARD PAINTED METAL FINISH

### E. LOW FILE STORAGE (OPTIONAL)

- 36" W x 18" D x 27" ± H (914 mm W x 457 mm D x 686 mm ± H)
- 2 DRAWER LATERAL c/w DIVIDERS, LEGAL/LETTER FILE HANGING BARS
- FLUSH BACK AND FINISHED TOP
- ANTI-TIP

### F. LOW OPEN STORAGE (OPTIONAL)

- 36" W x 18" D x 27" ± H (914 mm W x 457 mm D x 686 mm ± H)
- ONE SHELF
- FLUSH BACK AND FINISHED TOP



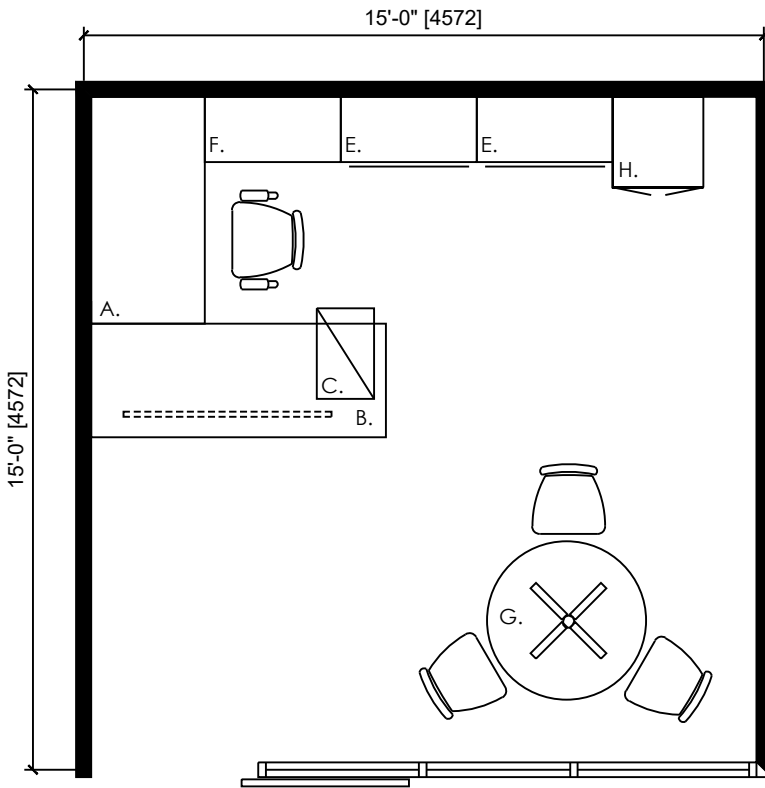

6 ASSISTANT DEPUTY MINISTER (AND EQUIVALENT) OFFICE  
20.9 m<sup>2</sup>

**FINISHES:**

- WOOD VENEER TOP AND BODY (STANDARD GRADE)
- SQUARE PROFILE EDGE
- FLUSH BACKS AND FINISHED TOPS
- STANDARD METAL PULLS (ADA COMPLIANT)
- WHITEBOARD

**WORKSPACE KIT-OF-PARTS LEGEND:**



**A. PRIMARY WORKSURFACE**

- 30" D x 60" W (914 mm D x 1524 mm W)
- ELECTRIC HEIGHT ADJUSTABLE
- CABLE MANAGEMENT ALONG SIDE



**B. SECONDARY WORKSURFACE**

- 30" D x 78" W (610 mm D x 1982 mm W)
- PIN HEIGHT ADJUSTABLE POST LEGS (C-LEGS OPTIONAL)
- HALF HEIGHT 'DETACHABLE' MODESTY PANEL
- CABLE MANAGEMENT ALONG BACK



**C. MOBILE PEDESTAL (FINISHED TOP, NO CUSHION)**

- 22"-24" D (560mm-610 mm D)
- BOX/FILE DRAWERS c/w DIVIDERS, LEGAL/LETTER FILE HANGING BARS, PENCIL TRAY



**E. LOW FILE STORAGE (OPTIONAL)**

- 36" W x 18" D x 27" ± H (914 mm W x 457 mm D x 686 mm ± H)
- 2 DRAWER LATERAL c/w DIVIDERS, LEGAL/LETTER FILE HANGING BARS
- FLUSH BACK AND FINISHED TOP
- ANTI-TIP



**F. LOW OPEN STORAGE (OPTIONAL)**

- 36" W x 18" D x 27" ± H (914 mm W x 457 mm D x 686 mm ± H)
- ONE SHELF
- FLUSH BACK AND FINISHED TOP

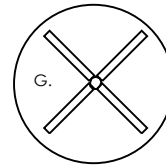

**G. DESK HEIGHT TABLE**

- 42" Dia. (1067 mm Dia.)
- METAL "X" BASE

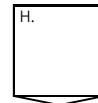

**H. CLOSED COMBINATION WARDROBE AND STORAGE CABINET**

- 24" D x 24" W x 66-72" H (610 mm D x 610 mm W x 1676-1828mm H)
- ANTI-TIP

**GENERAL NOTES**

1. REFER TO LEGEND SHEET A, AND SECTION 3 OF THE TECHNICAL DESIGN REQUIREMENTS.
2. WORKSPACE IS MEASURED FROM CENTRELINE OF WALL TO CENTRELINE OF WALL.
3. WORKSURFACES AND STORAGE SHALL HAVE DIMENSIONAL LOGIC AND CONSISTENCY.
4. ALL WORKSURFACES TO BE FREE-STANDING (NON-PANEL HUNG).
5. ALL STORAGE TO BE LOCKABLE AND KEYPED ALIKE.
6. COMPONENTS LISTED AS OPTIONAL CAN BE MIXED AND MATCHED, OR OMITTED.
7. CHAIRS ARE SHOWN FOR ILLUSTRATION ONLY.
8. THE OVERALL LENGTH AND WIDTH OF THE ENCLOSED OFFICES MAY VARY TO SUIT SITE CONDITIONS, SO LONG AS THE SPACE REMAINS USEABLE, AND THE SIZE (SQ.M) IS MAINTAINED.

	CONSULTANT	PROJECT	DRAWN BY	CHECKED BY	SCALE
		TECHNICAL DESIGN REQUIREMENTS VERSION 7- ADDENDUM #1	JH	KM	NTS
	DOCUMENT CODE WORKSPACE FURNITURE TYPICALS_APPENDIX I_TDR.V7_ADD_2024	TITLE	DATE	SITE ID	BUILDING ID
	ASSISTANT DEPUTY MINISTER (& EQUIVALENT)	TYPICAL WORKSPACE-	2024-09-04	-	-
		ASSISTANT DEPUTY MINISTER (& EQUIVALENT)	PLAN NO.	PHASE	DISCIPLINE
			-	-	-
			PROJECT ID.	SHEET NO.	
			Appendix I	6	

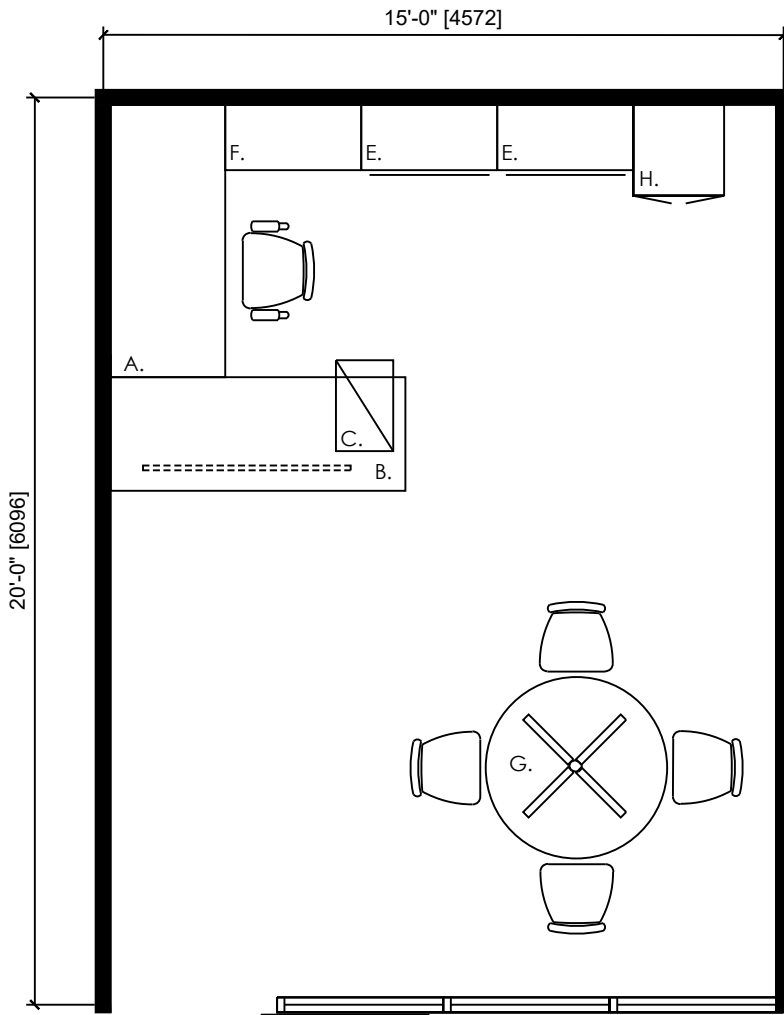

## WORKSPACE KIT-OF-PARTS LEGEND:

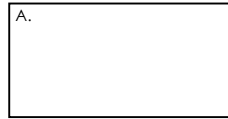

### A. PRIMARY WORKSURFACE

- 30" D x 72" W (914 mm D x 1828 mm W)
- ELECTRIC HEIGHT ADJUSTABLE
- CABLE MANAGEMENT ALONG SIDE



### B. SECONDARY WORKSURFACE

- 30" D x 78" W (610 mm D x 1828 mm W)
- PIN HEIGHT ADJUSTABLE POST LEGS (C-LEGS OPTIONAL)
- HALF HEIGHT 'DETACHABLE' MODESTY PANEL
- CABLE MANAGEMENT ALONG BACK



### C. MOBILE PEDESTAL (FINISHED TOP, NO CUSHION)

- 22"-24" D (560mm-610 mm D)
- BOX/FILE DRAWERS c/w DIVIDERS, LEGAL/LETTER FILE HANGING BARS, PENCIL TRAY



### E. LOW FILE STORAGE (OPTIONAL)

- 36" W x 18" D x 27"± H (914 mm W x 457 mm D x 686 mm ± H)
- 2 DRAWER LATERAL c/w DIVIDERS, LEGAL/LETTER FILE HANGING BARS
- FLUSH BACK AND FINISHED TOP
- ANTI-TIP



### F. LOW OPEN STORAGE (OPTIONAL)

- 36" W x 18" D x 27"± H (914 mm W x 457 mm D x 686 mm ± H)
- ONE SHELF
- FLUSH BACK AND FINISHED TOP

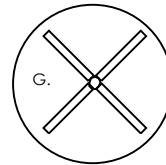

### G. DESK HEIGHT TABLE

- 48" Dia. (1219 mm Dia.)
- METAL TULIP BASE

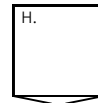

### H. CLOSED COMBINATION WARDROBE AND STORAGE CABINET

- 24" D x 24" W x 66-72" H (610 mm D x 610 mm W x 1676-1828mm H)
- ANTI-TIP

### GENERAL NOTES

1. REFER TO LEGEND SHEET A, AND SECTION 3 OF THE TECHNICAL DESIGN REQUIREMENTS.
2. WORKSPACE IS MEASURED FROM CENTRELINE OF WALL TO CENTRELINE OF WALL.
3. WORKSURFACES AND STORAGE SHALL HAVE DIMENSIONAL LOGIC AND CONSISTENCY.
4. ALL WORKSURFACES TO BE FREE-STANDING (NON-PANEL HUNG).
5. ALL STORAGE TO BE LOCKABLE AND KEYED ALIKE.
6. COMPONENTS LISTED AS OPTIONAL CAN BE MIXED AND MATCHED, OR OMITTED.
7. CHAIRS ARE SHOWN FOR ILLUSTRATION ONLY.
9. THE OVERALL LENGTH AND WIDTH OF THE ENCLOSED OFFICES MAY VARY TO SUIT SITE CONDITIONS, SO LONG AS THE SPACE REMAINS USEABLE, AND THE SIZE (SQ.M) IS MAINTAINED.

### FINISHES:

- WOOD VENEER TOP AND BODY (STANDARD GRADE)
- REVERSE CHAMFER EDGE PROFILE
- FLUSH BACKS AND FINISHED TOPS
- UPGRADED METAL PULLS, IF AVAILABLE (ADA COMPLIANT)
- WHITEBOARD

7 DEPUTY MINISTER (AND EQUIVALENT) OFFICE  
27.9 m<sup>2</sup>